

**POLITECHNIKA WARSZAWSKA**  
**WYDZIAŁ GEODEZJI I KARTOGRAFII**  
**KATEDRA GEODEZJI I ASTRONOMII GEODEZYJNEJ**

---

**No. 2 (87), 2009**

**RESEARCH CONTRIBUTIONS IN THE FIELD  
OF ENGINEERING SURVEYING  
WITHIN THE PERIOD 2007 – 2008**

**REPORTS ON GEODESY**

---

**WARSAW UNIVERSITY OF TECHNOLOGY**  
**FACULTY OF GEODESY AND CARTOGRAPHY**  
**DEPARTMENT OF GEODESY AND GEODETIC ASTRONOMY**

## **PRECISION LEVELING WITH USE OF BROKEN AIMING LINES**

**Kazimierz Ćmielewski, Janusz Kuchmister, Krzysztof Mąkowski, Bartłomiej Ćmielewski**

**Wroclaw University of Environmental and Life Sciences**

### **1. INTRODUCTION**

**Geometric connections of elements and engineering sub-elements for realization stage of measurements and also control measurements are set by geodetic measurements and most often height values occur where line, angle during leveling measurements of engineer objects observation disadvantages occur. Their sources come from the following factors:**

**Environment:**

- **Aggravated access to measuring points because of covering or location in places in connection with construction.**

**Instruments:**

- **Diversity of aiming line length which influence non-leveling of aim axis in appointed openings.**

**Instruments:**

- **Diversity of aiming lines height and opening measurements errors occurrence because of non-leveling of rods.**
- **Sizes and shapes of rods which are not adapted to the conditions of a rod on the object.**

**A range of technological processes in industrial conditions are carried out in small – spaced closed objects. Geometrical conditions included in project directions for a net of elements of technological networks of modern solutions are very often guarded by precise measurements of a 100th part of millimeter. The objects in the state of being built or measurement control are accessible in a short time limit. It requires adaptation of geodetic techniques to building techniques which is established at the site. The most common occurring drawback of measurements are changeable access conditions for height marks placed at the site. To improve observation techniques, the authors elaborated the design of a reflection device as a prototype which is to serve for leveling observations of the points not-accessible by use of broken aim lines.**

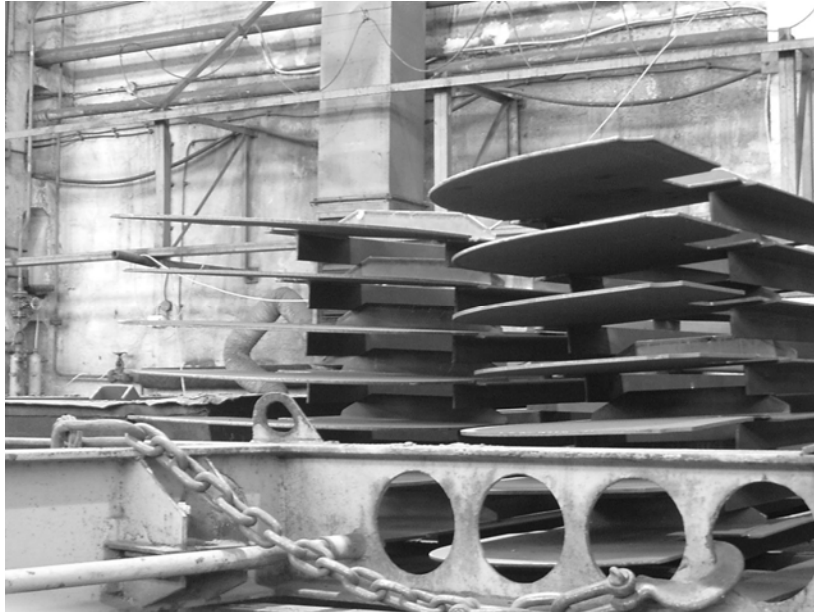

**Photo 1. Industrial hall. Covering of a bench mark connection while leveling of a construction base**



**Photo 2. Observation post covered by production waste**

## **2. REFLECTION DEVICE FOR AIM DEFLECTION LEVELING PURPOSES**

**The construction of a reflection device has been shown in fig. 1. The base element of the device is a precise autocollimation mirror made by Carl Zeiss Jena company.**

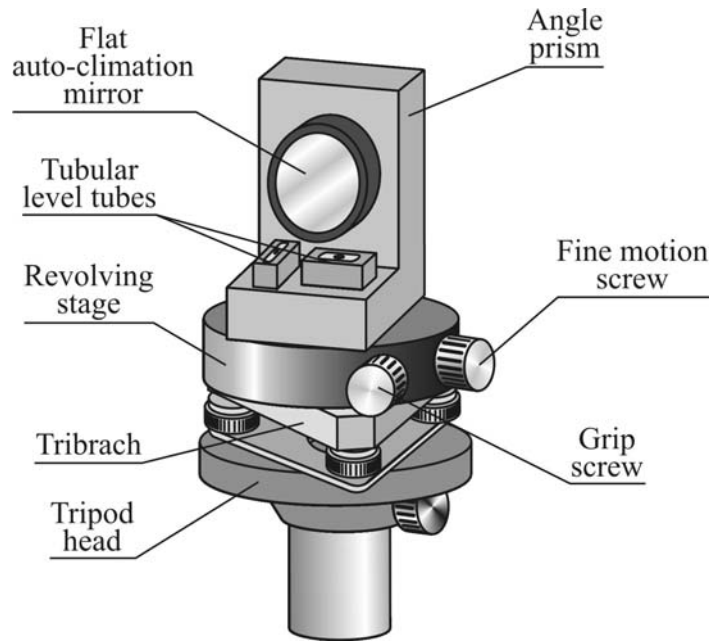

**Fig. 1. Construction of a reflection device.**

**The mirror is positioned in a vertical way on an angle prism which is stable connected to a revolving table which allows receiving a full observation horizon while a leveling aiming line is broken. Precision of the vertical position of the mirror is achieved by the use of tubular leveling tubes with appropriately chosen ballast.**

**In photos 3 and 4 we present a prototype of a reflection device.**

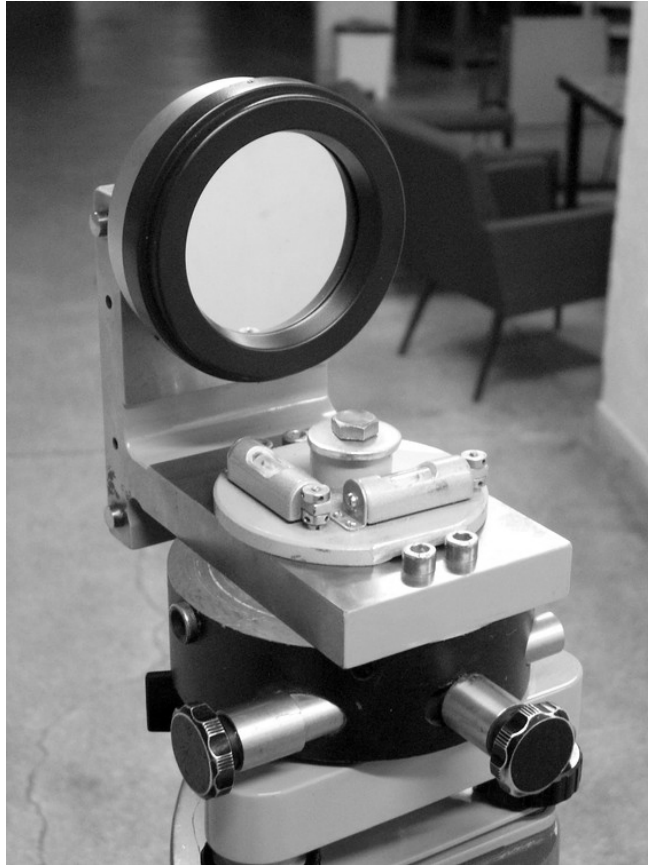

**Photo 3. Reflecting device on measuring post**



**Photo 4. The reflecting device is placed on a tripod where a measuring head is situated in the vertical position**

The visible mirror has an active diameter of 65 mm. The reflection is carried out by way of its flat front surface. The mirror is equipped with a magnet which allows connection to an angle prism.

Presently produced tripods for aims of engineering measurements can be equipped with movable vertical heads. They allow free regulation of the level of axis height of the aiming line in a defined range in cases of leveling measurements. Usage of the above mentioned tripod in a set together with reflection device makes possible a fast adjustment of location of height of broken aiming line when bypassing obstacles.

### 3. EXAMPLES OF USES OF THE REFLECTING DEVICE

Examples of using reflecting devices were shown in fig. 2 and 3 for singular and multiply breaking aiming line. Nowadays a code level plays a vital part in measuring at uncovered engineering objects. But at covered objects with special conditioning (under-lighting, pollution, etc), optical levels show better measuring possibilities (it occurs because of the physiology of the eye of the observer and its psych-physiological possibilities), (Tatarczyk 1995).

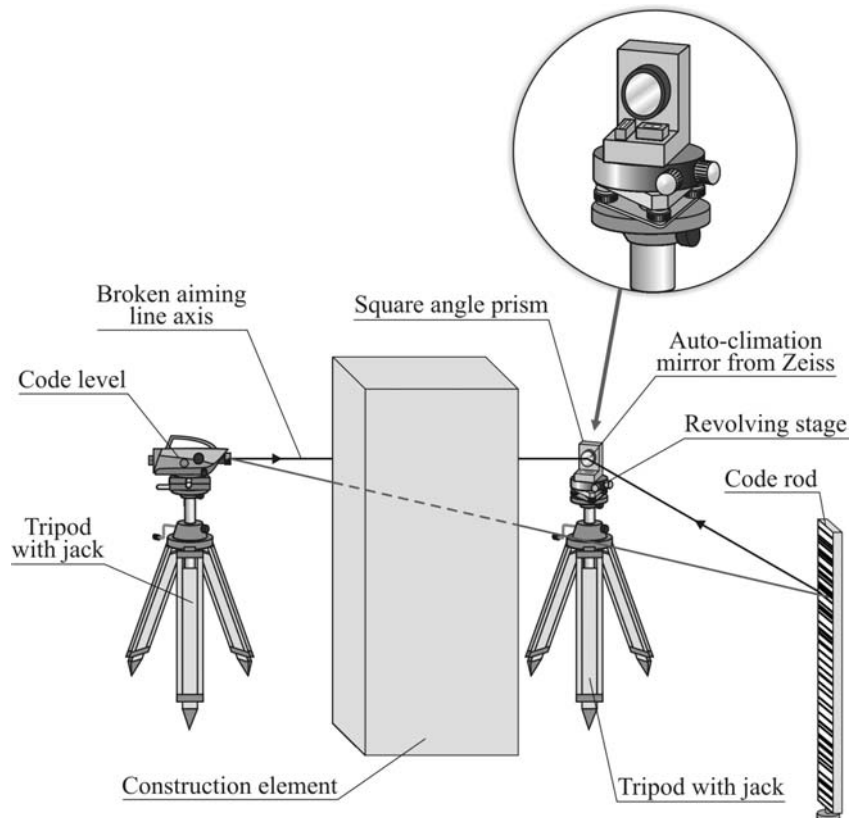
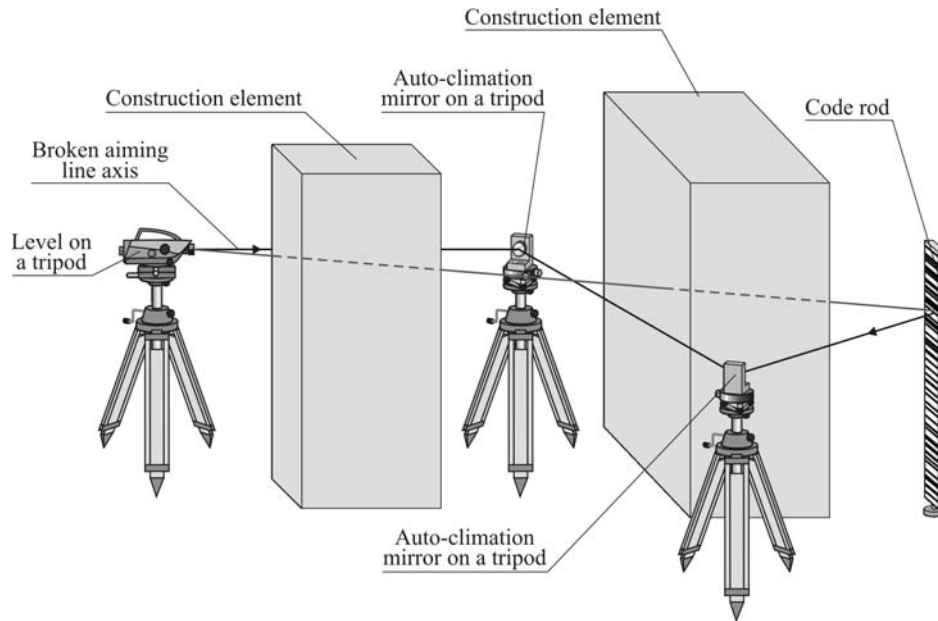

Fig. 2. Leveling measurement with a code level with singular broken aiming line.



**Fig. 3. Leveling measurement with a code level with double broken aiming line.**

#### **4. TEST RESEARCHES**

**For defining the initial function and precision parameters of a reflecting device, a prototype was built and a series of tests was run. For experimental researches a code level DNA03 from Leica was used and a code invar rod as well as a prototype of a reflection device, as shown in photos 5, 6 and 7.**

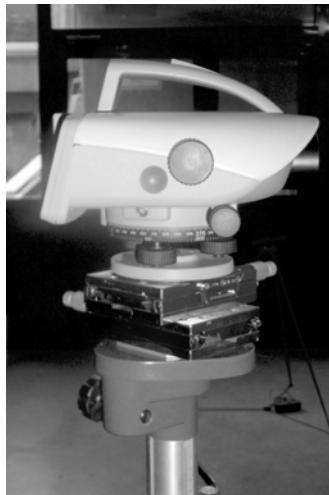

**Photo 5. Level DNA03 in the measuring position**

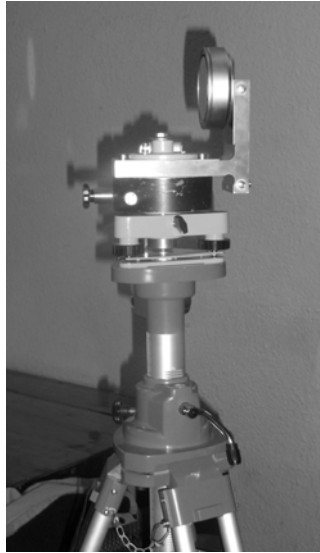

**Photo 6. Reflection device in the process of breaking the level aiming line**



**Photo 7. Code rod set on a test bench mark**

**Initial test results in order to define leveling possibilities of measurement with use of a reflecting device were made by way of experimental works at a laboratory leveling base located in a basement of the Geodesy and Geo-Computer science Institute in Wrocław. The experiment was based on two, independent definition of a waist between of two height points: without use of a reflection device and with use of a reflection device. The results of measurements were put in the form of a table. Next minimal and maximal values of aiming lines lengths possible to carry out with a use of reflecting devise were defined.**

**The range of a vertical angle of leveling rode possible to be set was also established. Measuring works were carried out on two levels: DNA03 from Leica and Ni007 from Zeiss.**



## 5. SUMMARY

Companies which produce geodetic equipment and measuring devices require, often at engineering objects, use of additional aid equipment which allows widening observation techniques. Initial researches allow adjusting of a reflection device. Minimal and maximal aiming lines possible to carry out with use of a reflecting device for tested levels do not differ from those given by the producers. Thanks to the use of a revolving stage (fig.1), horizontal angle in a range that allows carrying out leveling measurements is 45 degrees. Precision of leveling measurements carried out by a reflection device do not differ from those performed without use of a reflecting device.

## REFERENCES

- Bryś H., Przewłocki S., 1998. Geodezyjne metody pomiarów przemieszczeń budowli. Wydawnictwo Naukowe PWN, Warszawa.
- Gil J., 2007. Geodezyjne pomiary inżynierskie. Wydawnictwo Politechniki Zielonogórskiej.
- Gocał J., 1993. Metody i instrumenty geodezyjne w precyzyjnych pomiarach maszyn i urządzeń mechanicznych. Wydawnictwo AGH, Kraków.
- Janusz J., 1993. Metoda wyznaczania przemieszczeń punktów z wykorzystaniem odbić zwierciadlanych. Konferencja Naukowo-Techniczna pt.: „Problemy Automatyzacji w Geodezji Inżynierskiej”, Warszawa.
- Janusz W., 1975. Obsługa geodezyjna budowli i konstrukcji. PPWK, Warszawa.
- Prospekty firm: Topcon, Leica, Zeiss, Kern.
- Tatarczyk J., 1984. Elementy optyki instrumentalnej i fizjologicznej. Skrypt AGH nr 940, Kraków.